

## Recommended ISA Course Sequencing for **BBA-ISA Majors**

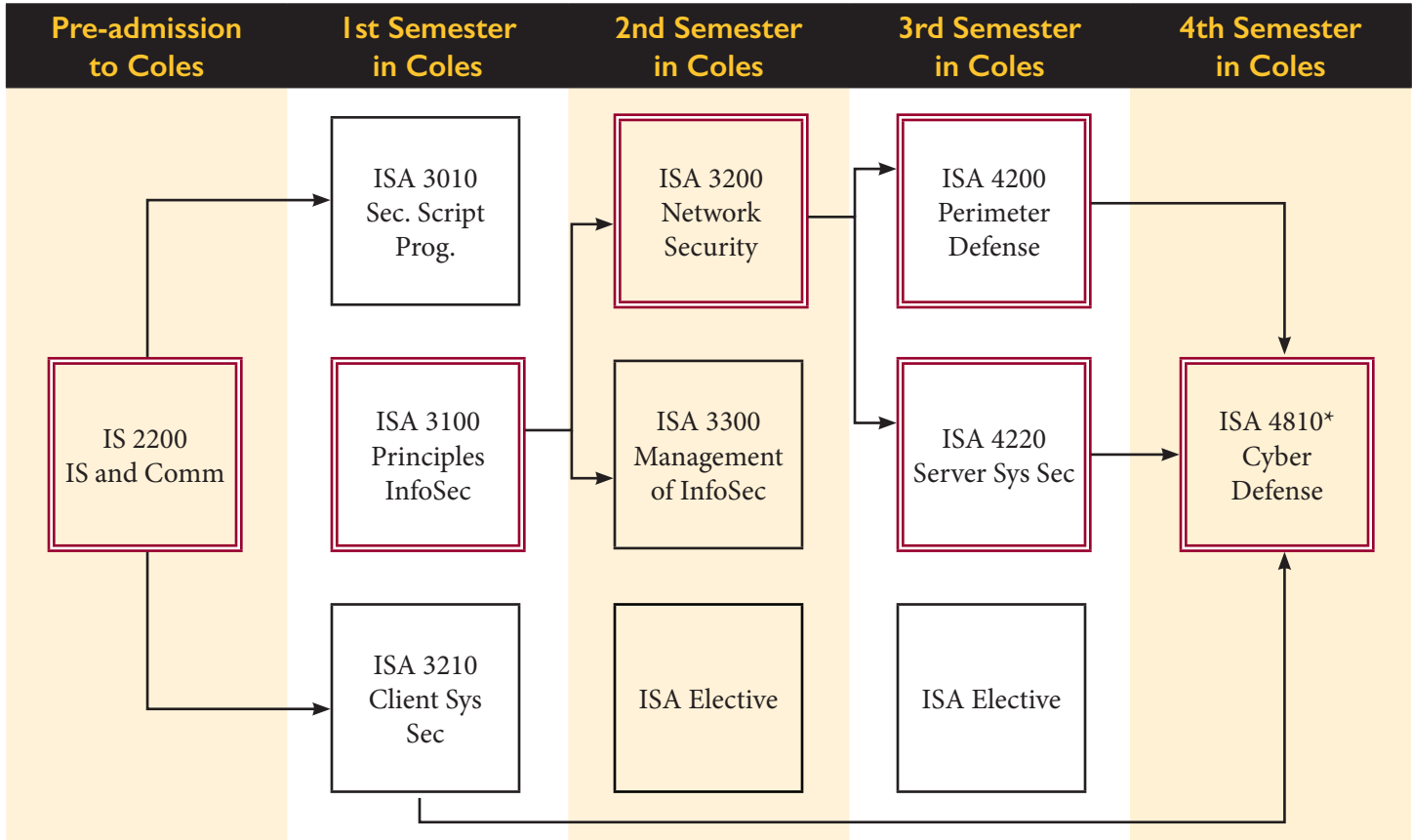

→ Arrows indicate pre-requisite structure.

Strongly recommend timing.

These courses are easily moved.

\* Please note, this course is not offered in the summer semester.

### ELECTIVES WITHOUT PRE-REQS

ISA 3710 International Issues in ISA

ISA 4400 Directed Study

ISA 4490 Special Topics

### ELECTIVES WITH PRE-REQS

IS 3920 Application Development II (IS 3020 or ISA 3010)

ISA 4330 Incident Response & Contingency Planning (ISA3300)

ISA 4350 Digital Forensics (ISA 3210, ISA 3200)

ISA 4805 Penetration Testing (ISA 3200, ISA 3210)

**The IS Department Chair will approve additional substitutions as BBA-ISA Major Electives from:**

Any IS prefix course

Any ISA Prefix course except ISA 3330 that may not be included in your catalog

**Some CRJU courses:**

CRJU 1101 Foundations of Criminal Justice  
(pre-req for the following)

**And then in order of value to you as an ISA major:**

CRJU 4305 Technology and Cyber Crime

CRJU 3305 Technology and Criminal Justice

CRJU 3320 Criminal Investigation any other CRJU courses

**Some CS and IT courses that include security related topics**

**Some Accounting courses (these will have additional pre-reqs):**

ACCT 3300 Accounting Information Systems

ACCT 4150 Auditing and Assurance

ACCT 4152 Internal Auditing

ACCT 4350 Accounting Systems Audit and Control

**NOTE:** All of these are 3 class hours, 0 laboratory hours, 3 credit hours.

### **ISA 3010 - Security Script Programming**

This course provides a study of secure programming and security scripting techniques. The course examines aspects of developing traditional computer software, applying additional controls and measures to prevent the development of vulnerable and exploitable code. The course then examines scripting techniques used in support of ongoing technical security functions.

### **ISA 3100 - Principles of Information Security**

An introduction to the various technical and administrative aspects of Information Security and Assurance. This course provides the foundation for understanding the key issues associated with protecting information assets, determining the levels of protection and response to security incidents, and designing a consistent, reasonable information security system, with appropriate intrusion detection and reporting features.

### **ISA 3200 - Network Security**

*Prerequisite: ISA 3100*

This course provides a detailed examination of tools, techniques, and technologies used in the protection of information assets. This course is designed to provide a solid foundation in data communications and networking fundamentals and the security of networks and networking technologies.

### **ISA 3210 - Client Systems Security**

This course is an exploration of client computer system security and vulnerabilities, including client computer architectures, and operating systems. It provides the detailed technical coverage necessary to protect computer information system clients by presenting the knowledge of client platform computer hardware components, client network devices and interfaces, as well as the structure and usage of common client operating system software from an information security perspective. Additional learning regarding ongoing maintenance and operational issues of client computing systems will also be included.

### **ISA 3300 - Management of Information Security in a Global Environment**

*Prerequisite: ISA 3100*

This course provides a detailed examination of the administration of the information security function beginning with the strategic planning process and including an examination of the policies, procedures, and staffing functions necessary to organize and administrate ongoing security functions in the organization. Subjects include security practices, security architecture security in light of international regulation, competition, and operating environments is emphasized throughout the course.

### **ISA 4200 - Perimeter Defense**

*Prerequisite: ISA 3200*

A detailed examination of the techniques, tools, and technologies used to support the protection of an organization's electronic perimeter. The course will examine the evaluation, selection, deployment, and administration of firewall, virtual private network, intrusion detection and prevention systems, and other applications used to guard organizational information from external attacks.

### **ISA 4220 - Server Systems Security**

*Prerequisite: ISA 3010 and ISA 3200*

This course is an exploration of server computer system security and vulnerabilities, including server computer architectures, and operating systems. It provides the detailed technical coverage necessary to protect computer information system servers by presenting the knowledge of server platform computer hardware components, server network devices and interfaces, as well as the structure and usage of common server operating system software from an information security perspective. Additional learning regarding ongoing maintenance and operational issues of server computing systems will also be included.

### **ISA 4330 - Incident Response and Contingency Planning**

*Prerequisite: ISA 3300*

An examination of the detailed aspects of incident response and contingency planning consisting of incident response planning, disaster recovery planning, and business continuity planning. Developing and executing plans to deal with incidents in the organization is a critical function in information security. This course focuses on the planning processes for all three areas of contingency planning incident response, disaster recovery, and business continuity, and the execution of response to human and non-human incidents in compliance with these policies.

### **ISA 4350 - Management of Digital Forensics and eDiscovery**

*Prerequisite: ISA 3200 and ISA 3210*

This course focuses on the detection, isolation and response to security breaches and attacks. It provides a detailed examination of the entire computer forensic process and presents specific procedures required to respond to a computer crime incident. Subjects include recognizing unauthorized access, identifying file anomalies, and traffic monitoring.

### **ISA 4805 - Penetration Testing**

*Prerequisite: ISA 3210 AND ISA 3200*

This course contains a detailed examination of real world information security knowledge, enabling recognition of vulnerabilities, exploitation of system weaknesses, and implementation of safeguards against threats. Through hands-on exercises and a final project students will learn the art of penetration testing. Students who complete this course will be equipped with the knowledge necessary to analyze and evaluate systems security.

### **ISA 4810 - Cyber Defense**

*Prerequisite: ISA 3210, ISA 4200, and ISA 4220*

This course discusses the hardware/software tools and techniques associated with the protection of computer systems and networks. Students learn how to protect network resources as deployed in a typical organization. Course topics include policy and practice associated with the protection of communication resources, intrusion detection systems, firewalls, and use of various tools for system and network protection.